

Hood Protector

HD 20D15

Installation Instructions

Toyota Camry 2015-up

Kit Contents

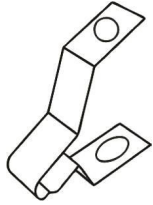

Metal brackets (3)

Screws (6)



Bumpons (3)

Pins (6)

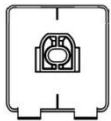

Adhesive pedestal with fingers (4)

Anti-abrasion pads (3)



Adhesive pedestal without fingers (2)

Push-type retainer (6)



(1)

Re-useable tape strips (1)

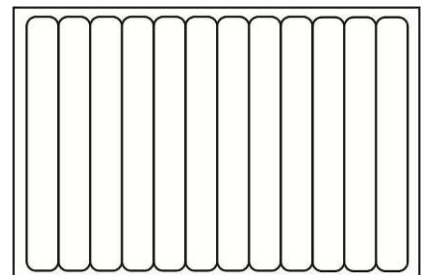

Hood protector blade (1)

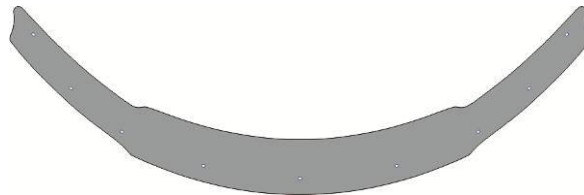

Installation Procedure

NOTE: Vehicle surface temperature should be a minimum 15 degrees Celsius.

1. Be sure that the hood is clean and dry inside and out.
2. Open the hood of the vehicle. Peel and fold the anti-abrasion pads in half over the edge of the hood, in line with the 3 (three) holes under the hood, as illustrated.

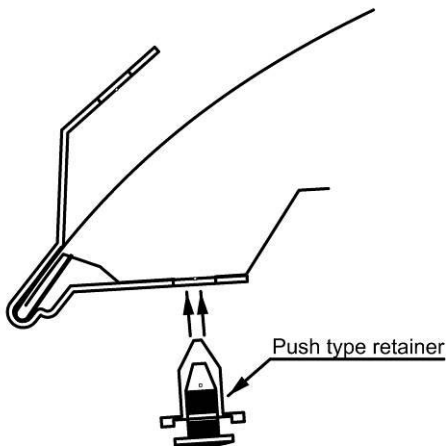
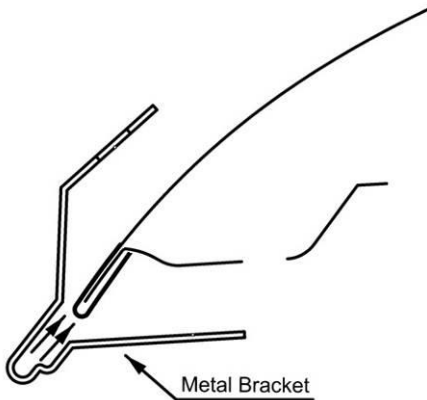
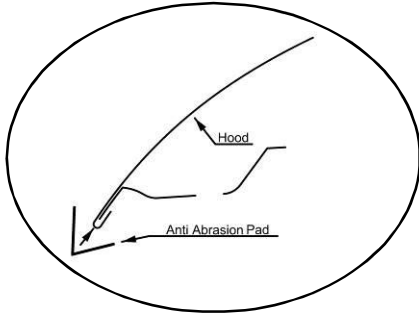
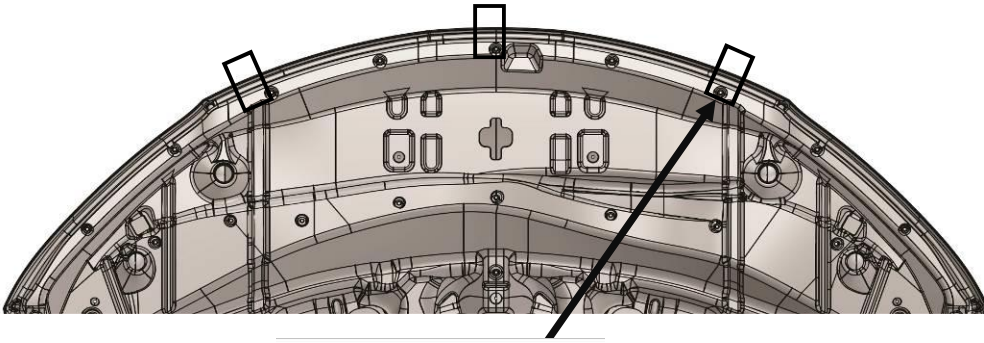

3. Install the three metal brackets on the hood edge over the anti-abrasion pads. Align the hole in the bottom leg of the bracket with the round hole in the hood. *See Illustration.*
4. Insert a push-type retainer through the metal bracket and into the hood. Ensure leg of the bracket is well seated against the surface of the hood and push the center pin of the retainer assembly to lock it into place. *See Illustration.*



NOTE: Engaging the center pin of the push-type retainer is best accomplished by placing a #2 Philips drive screwdriver into the recess of the center pin and pushing the pin followed by tightening 90 degrees to fully engage the retainer into the hood. The retainer can be removed by unthreading the center pin with a Philips screwdriver, however initial installation is best done using the push method described above.

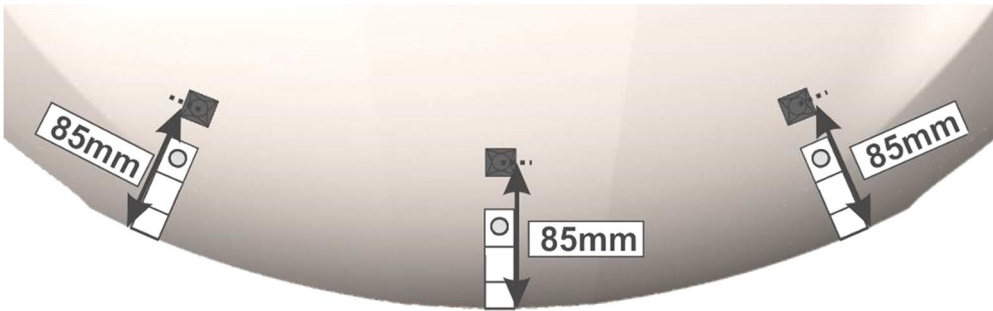

5. Install the three (3) bumpons as shown. Attention: the bumpons must be installed on the hood, not on the deflector!!! If the bumpons are installed on the deflector, they may wear through the paint.

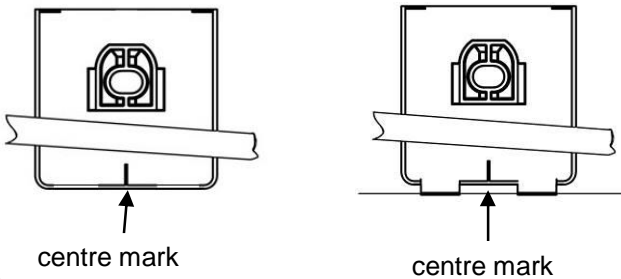

6. Test fit the adhesive pedestals using the supplied tape strips or masking tape to temporarily hold them in position.

The locations of the pedestals can be determined in two ways;

a) Use the measurements shown in **illustration**. Always measure to the center mark on the leading edge of the pedestal. *Note: Measure to the centre mark on the pedestals, not to the hood edge.*

OR

b) Use the paper template supplied (last page). Follow the instructions on the template for correct positioning of the two outermost pedestals. Use measurement supplied to locate the third innermost pedestal.

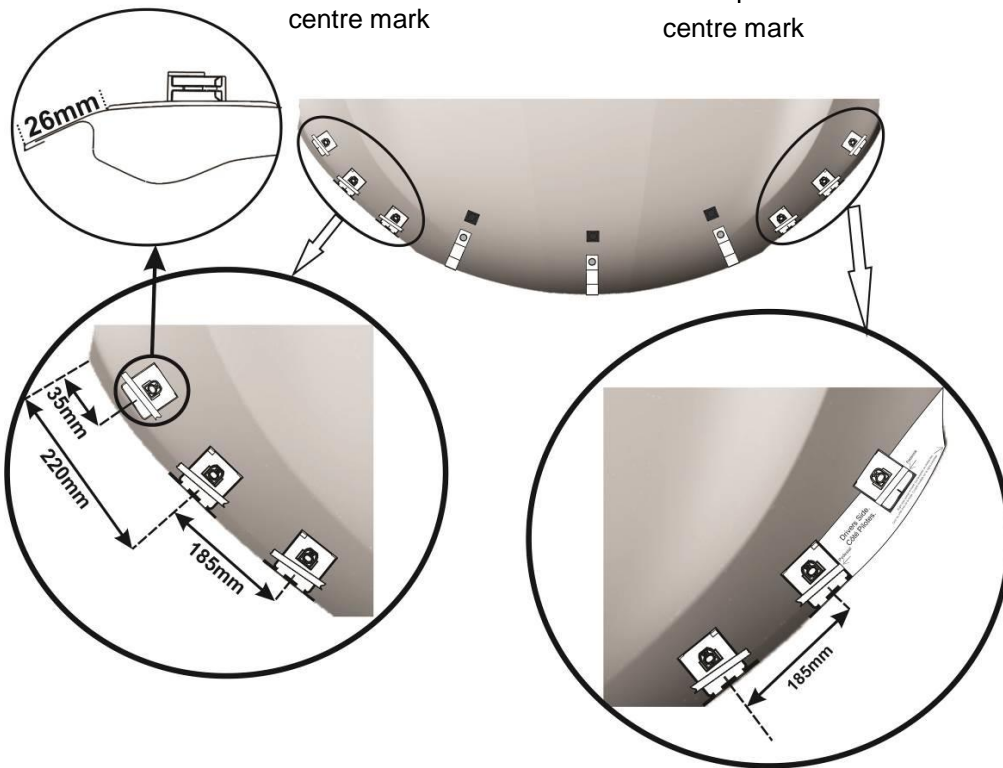

6A- using a tape measure to determine the positions of the pedestals

6B- using the template and a tape measure to determine the positions of the pedestals

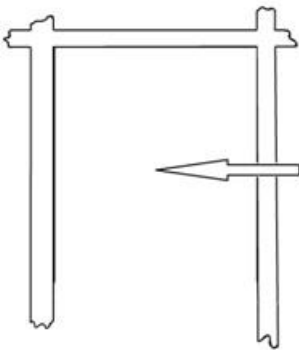
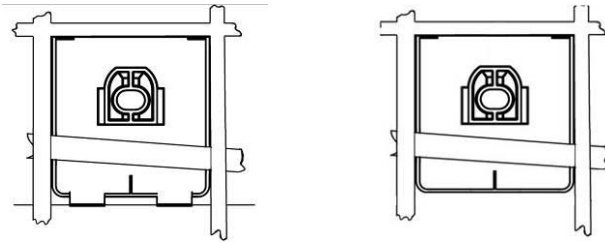
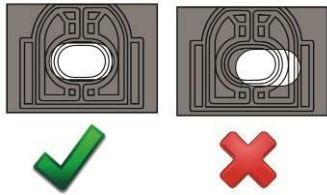
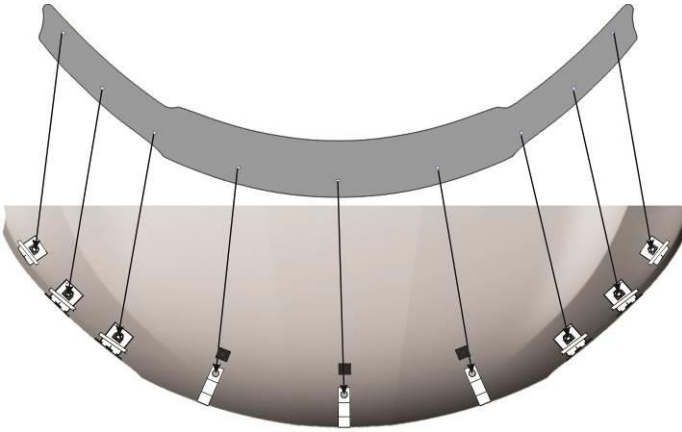

- Place the protector temporarily onto the metal brackets, aligning the holes in the protector with the holes in the metal brackets. This step will allow you to check the position of the adhesive pedestals and adjust if necessary.

- Remove the hood protector. Outline the perimeter of the adhesive pedestals with the tape strips or masking tape.



- Remove the pedestals and thoroughly clean the outlined area with the alcohol wiping pad and then dry with a paper towel or clean cloth. This will ensure all wax, finger prints and oils are removed from the hood surface where the pedestals need to install.

10. Remove the red protective backing from the pedestals.

- Use tape outlines to correctly position the adhesive pedestals on the hood.
- Remove the tape and wet out the adhesive to the hood surface by applying pressure with your thumb around the surface of the pedestals.

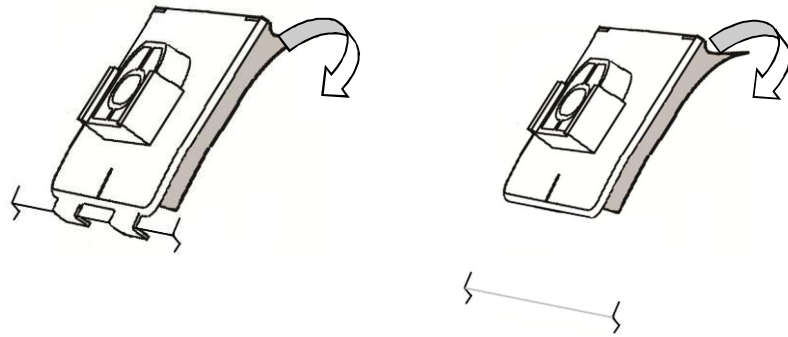

NOTE: *Be very careful to install the pedestals exactly as they were during the test fit.*

11. Start a screw into each pedestal a few turns. *See illustration.*



NOTE: The tip of the screw must not protrude into the hole where the attachment pin will install later.

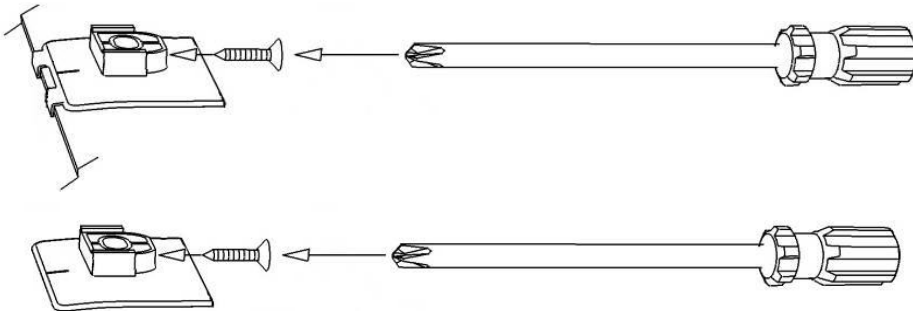

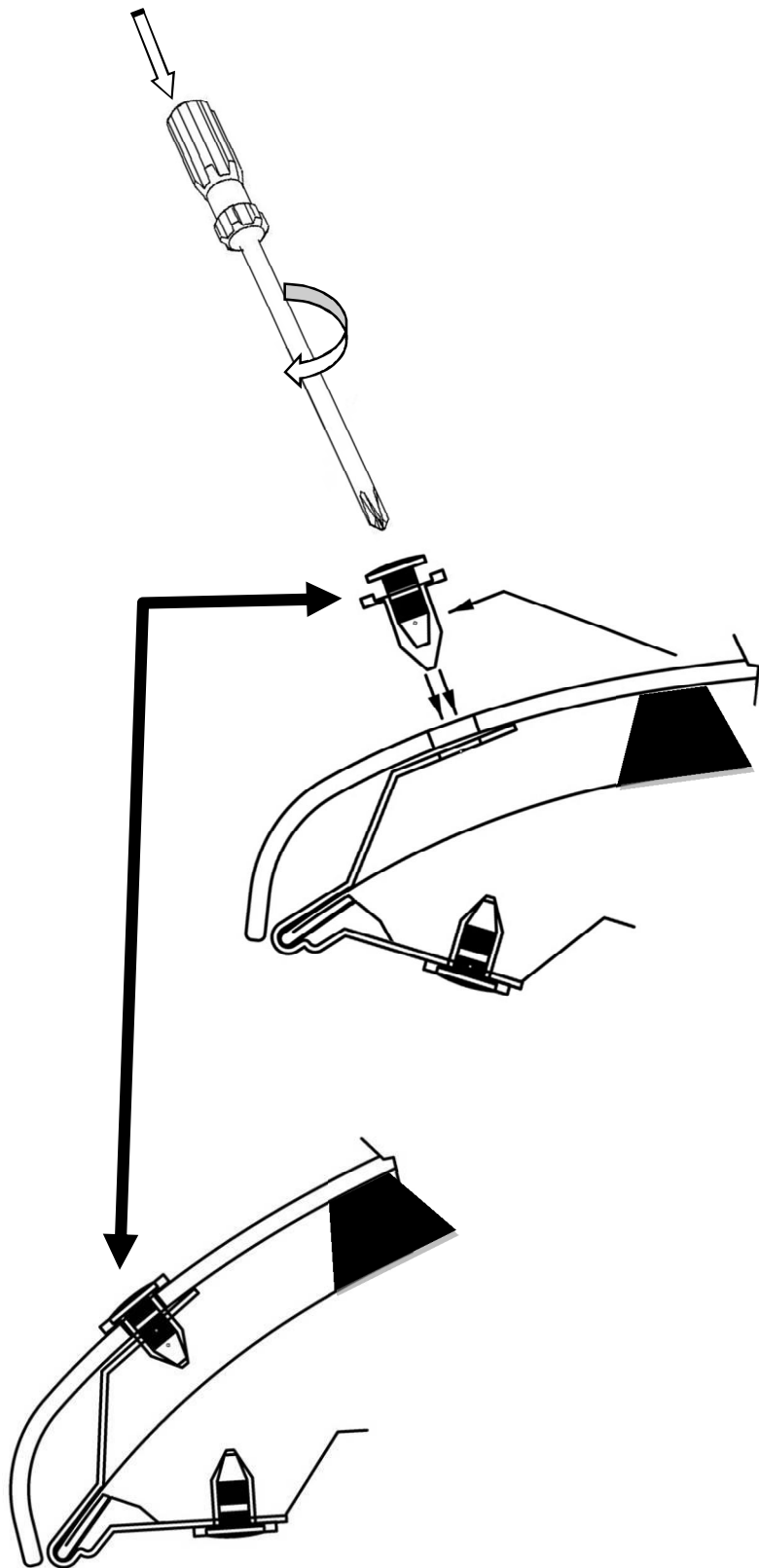

12. Place the protector on the hardware mounted to the hood and align the three (3) holes in the protector with the holes in the metal brackets.



- Insert a push-type retainer through the hole in the protector, and into the bracket.
- Ensure the protector is seated against the metal bracket, push the center pin of the retainer followed by tightening 90 degrees to fully engage the retainer into the metal bracket. Repeat for the remaining metal bracket locations.



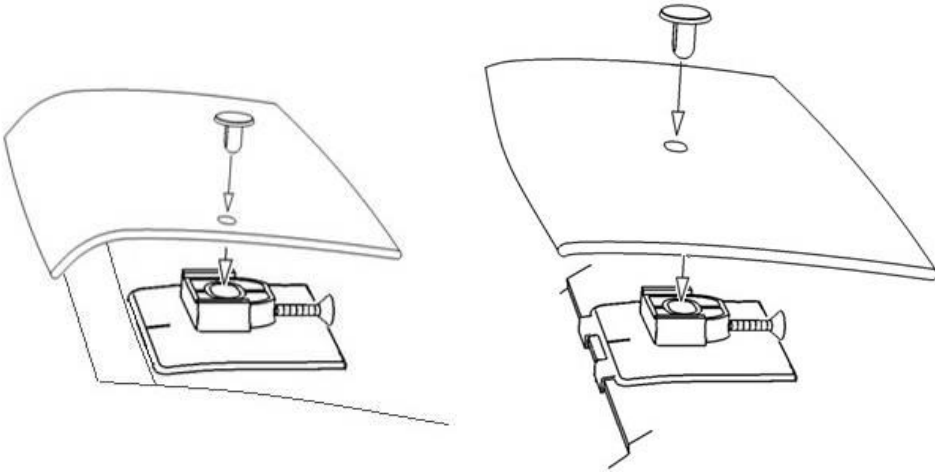

13. Starting at the inner most pedestal and working outward, insert a pin through the protector and into the pedestal. Maintain pressure on the head of the pin to ensure the protector is seated against the pedestal and tighten the screw until snug. Do not over-tighten!

CAUTION: Be sure to take care not to scratch or damage the hood surface while tightening the screws.

NOTE: Proper installation of the adhesive pedestal system requires the use of a #2 Phillips screwdriver, (long shaft). See illustration.

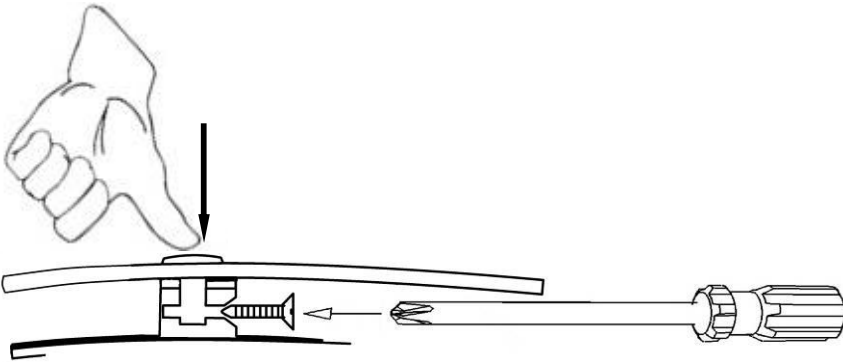

14. On some vehicles it may be necessary to adjust the hood bumpers and/or latch for proper clearance.

Note: Do not pull on the protector when opening or closing the hood.

CAUTION: Do not expose the vehicle/hood protector to extreme environments (weather) or car washes for a 24 hour period following the installation to allow the adhesive pedestals sufficient time to reach full bond strength.



CARE INSTRUCTIONS

Clean the protector with a mild soap and water solution or plastic cleaner only. Do not use chemicals or solvents. **Periodically check to make sure the bumpers are in place and the protector is secure. Avoid using automatic car washes.** Do not pull on the protector when opening or closing the hood.

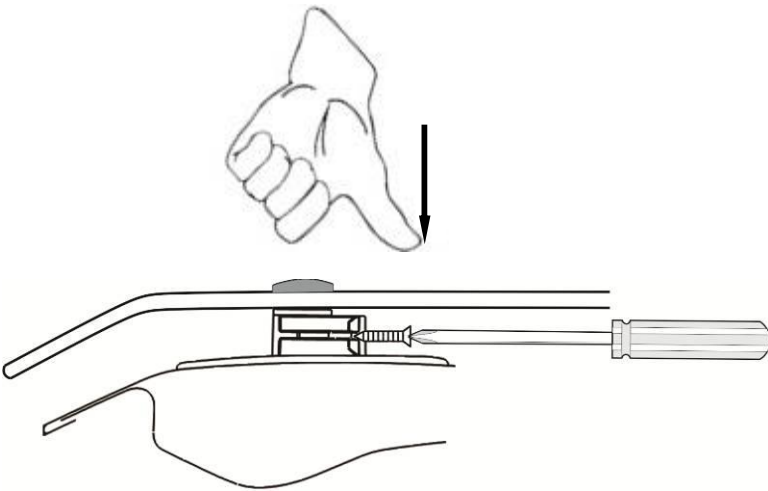

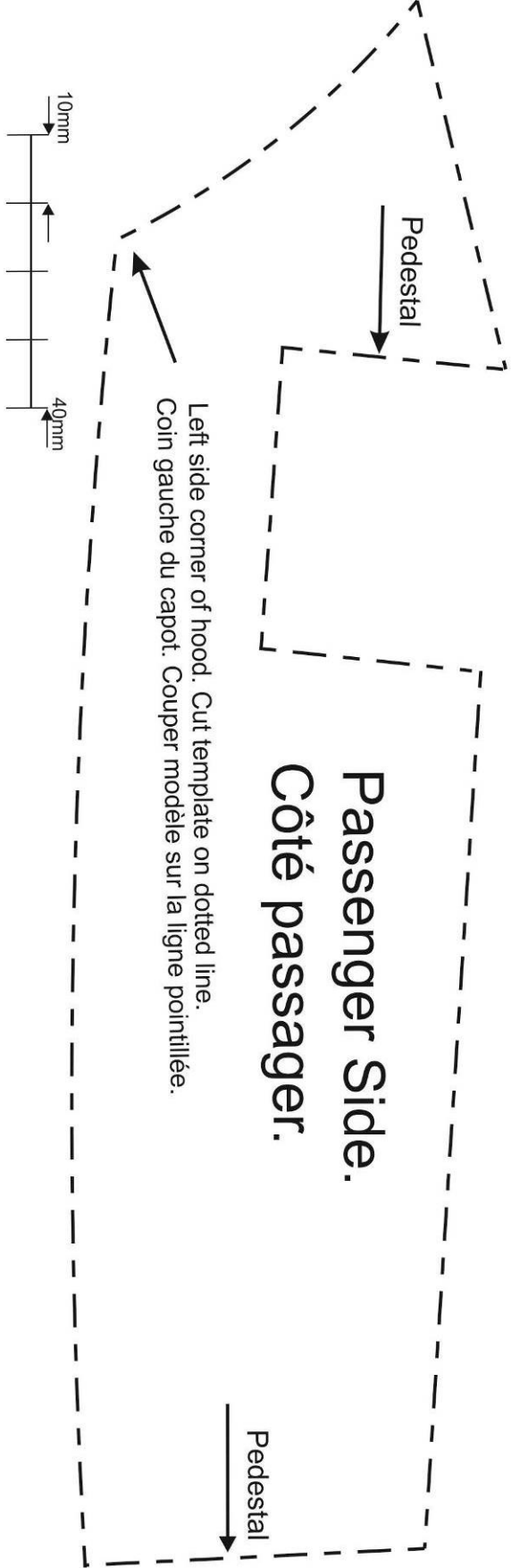
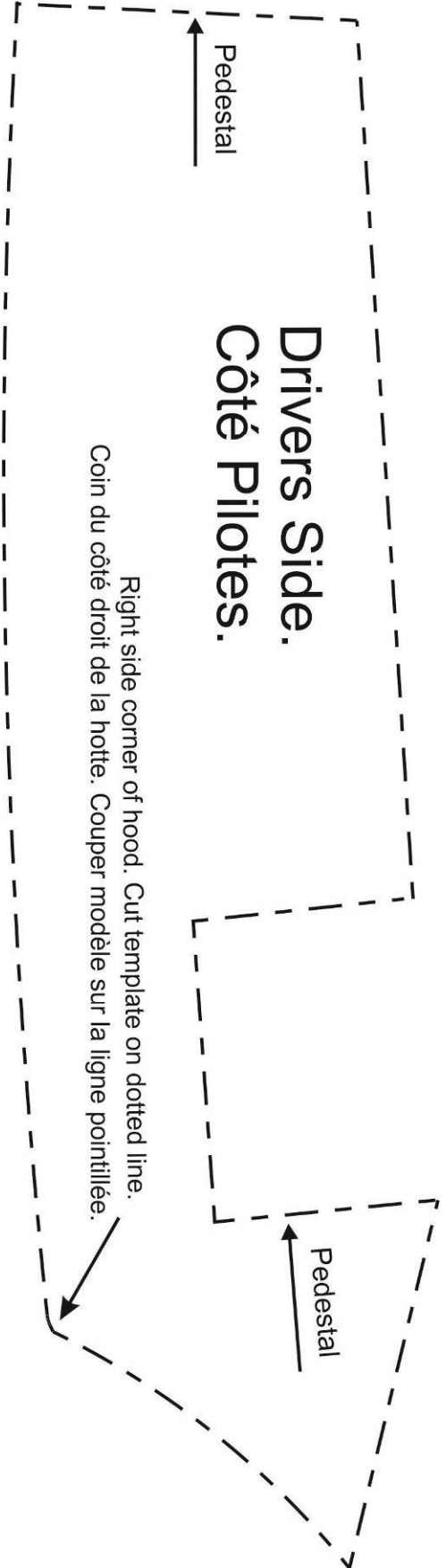

Set Printer Scale to 100% and Confirm

Réglez l'échelle de l'imprimante à 100% et Confirmer