

Kit Contents

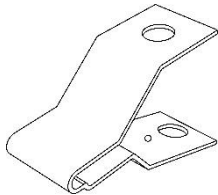

Anti-abrasion film pads (3)

Automotive surface cleaner (1)



Metal mounting bracket Type A (marked with a dot) (1)

Screws (2)

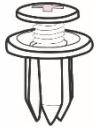

Push type retainer (6)

Pins (2)

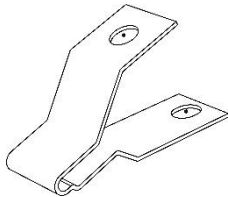

Metal mounting bracket Type B (2)

Tape strip sheet (1)

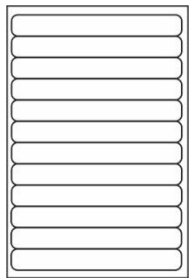

Round bumpons (5)

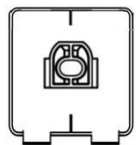

Small adhesive pedestals (2)

Hood deflector (1)



Installation drawings

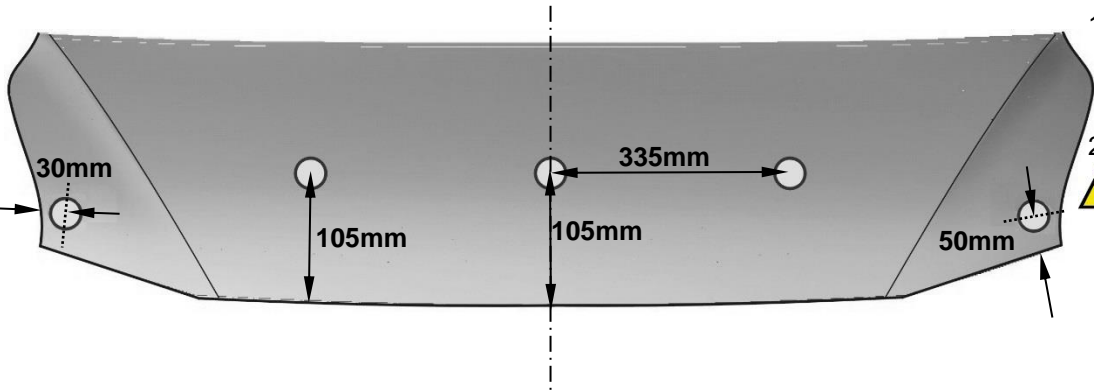

Installation Procedure

1. Be sure that the hood is clean and dry inside and out.
2. Install the five (5) bumpons as shown. **Attention: Bumpons must be installed on the hood, not on the deflector!!!** If the bumpons are installed on the deflector, they may wear through the paint. 
3. Open the hood of the vehicle. Peel and fold an anti-abrasion film pad in half over the edge of the hood, in the three (3) locations shown in illustration.

**Looking at underside of the hood
Anti-abrasion Pad and Metal Bracket Locations**

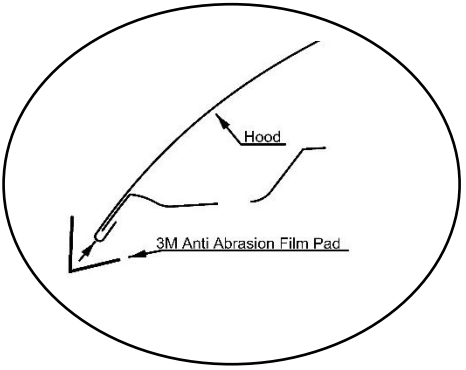
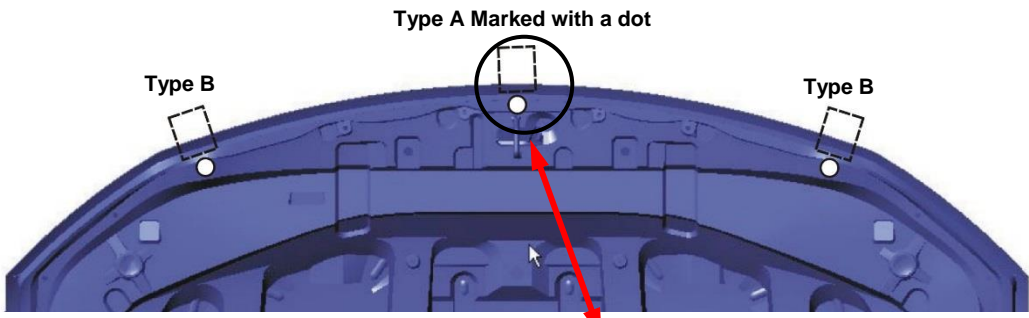

Metal Bracket Guide

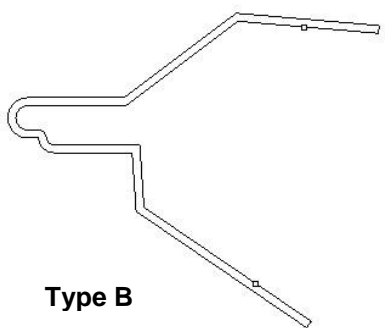
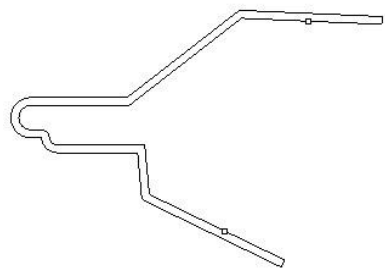

4. **NOTE: Use the metal Brackets Guide** to determine the type of bracket used in the following steps. See *Illustration*.

Type A Marked with a dot

Type B

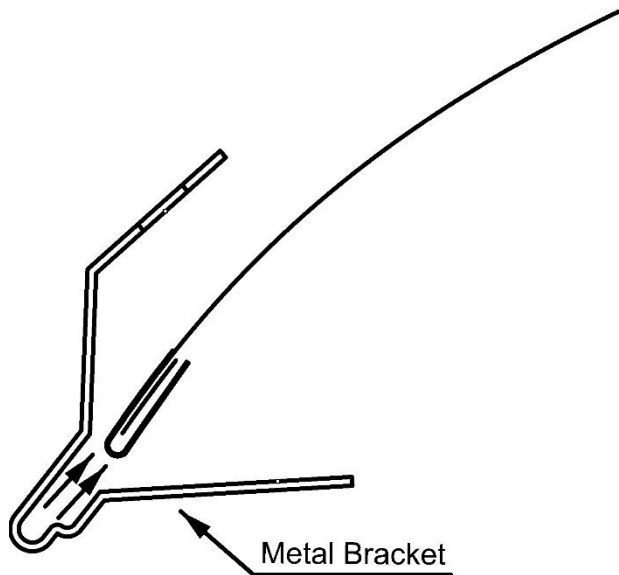

5. Install Metal Brackets over the hood edge in their correct positions.

 Align the hole in the bottom leg of the bracket with the round hole in the hood.

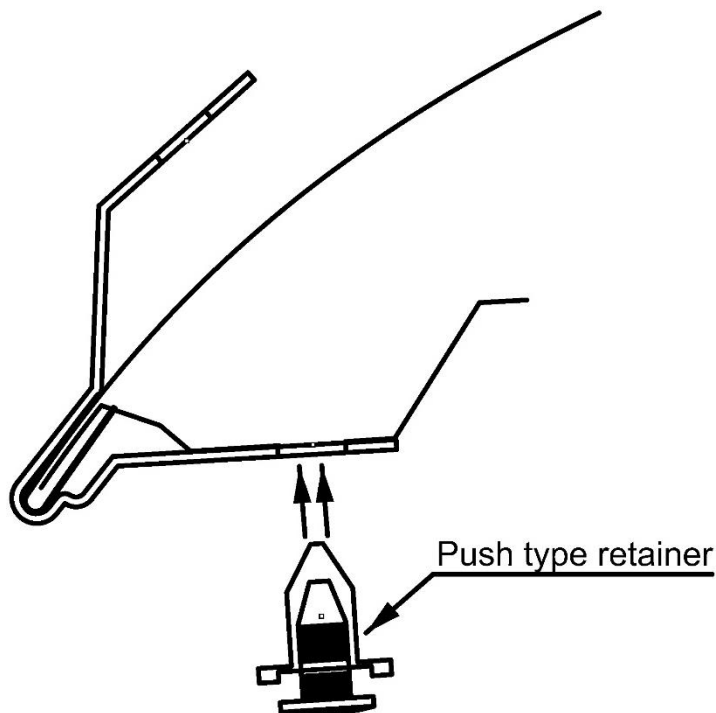

6.  Insert a push type retainer through the metal bracket and into the hood. Ensure leg of the bracket is well seated against the surface of the hood and push the center pin of the retainer assembly to lock it into place. See *Illustration*.

NOTE: Engaging the center pin of the “push type retainer” is best accomplished by placing a #2 Philips drive screwdriver into the recess of the center pin. Use a light force or tap on the end of the screwdriver to seat the pin into the retainer. The retainer can be removed by unthreading the center pin in the conventional manner with a Philips screwdriver, however initial or subsequent placement is best performed using the “push” method described above.



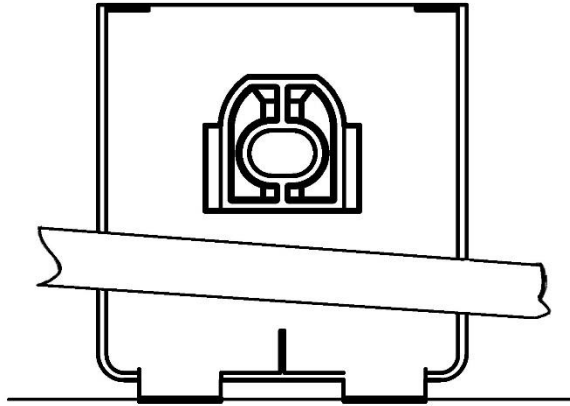

6. Dry fit the adhesive pedestals using masking tape or the repositionable tape strips supplied to hold them in position.

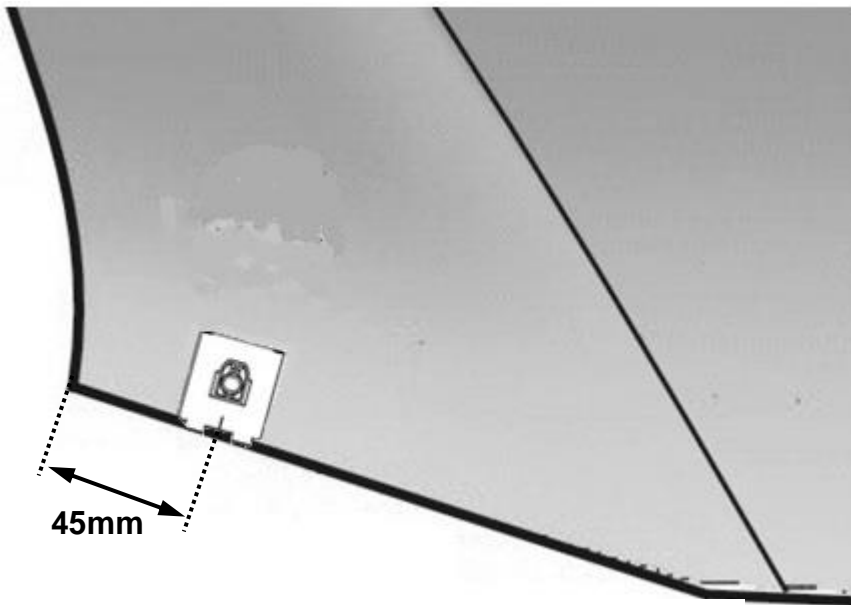

7. The positions of the pedestals are shown in **illustration**. Use the center mark on the leading edge of the pedestal for accurate measuring. The fingers incorporated on the leading edge of the pedestal will help ensure the correct position relative to the hood edge. When correctly positioned the fingers should contact the leading edge of the hood.

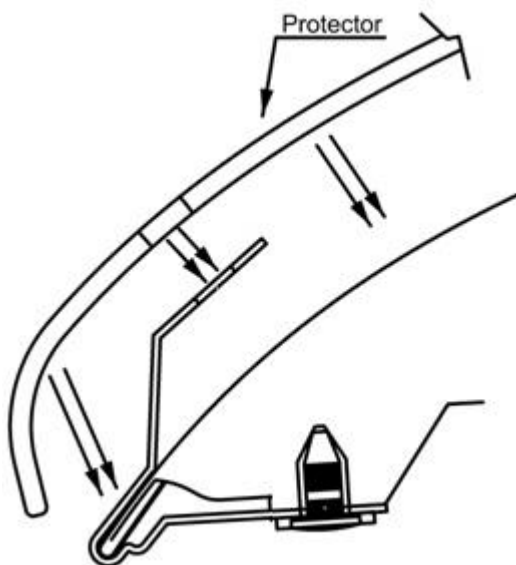

8. Place the protector temporarily onto the metal brackets aligning the holes in the protector with the holes in the metal brackets. This step will allow you to confirm the position of the adhesive pedestals.

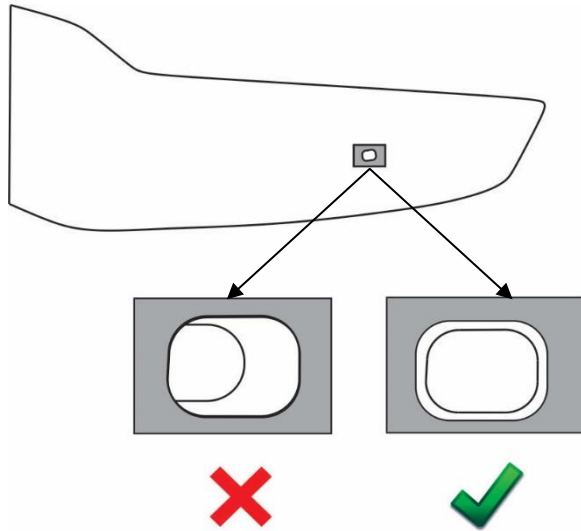

9. Confirm correct positioning of the pedestals, by adjusting the pedestal position on the hood to align with the holes in the hood protector.

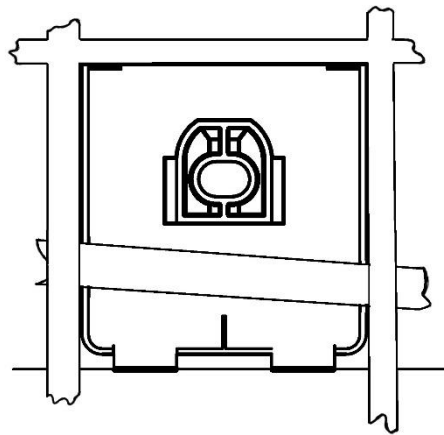

10. Remove the hood protector, and outline the perimeter of the pedestals with masking tape or the repositionable tape strips supplied to help final installation.

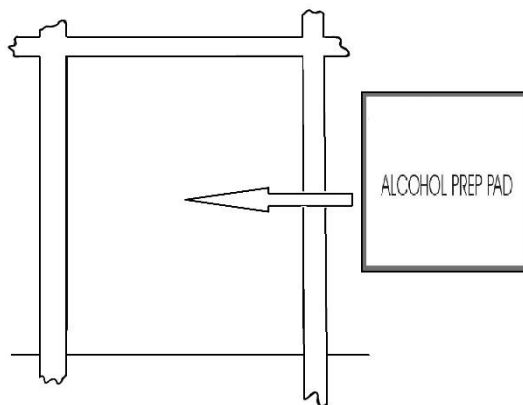

11. Remove the pedestals and thoroughly clean the outlined area with the alcohol wiping pad. This will insure all wax, finger prints and oils are removed from the hood surface in the bonding area.

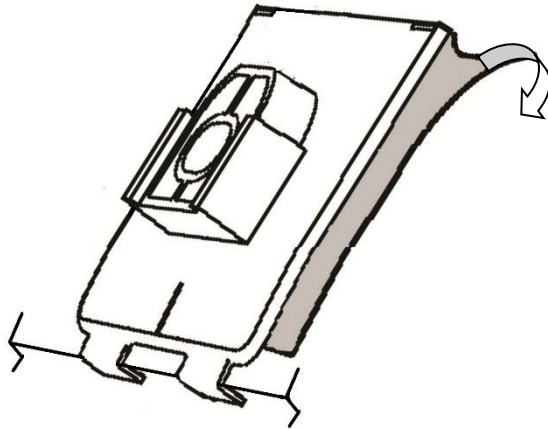

12. Remove the protective backing from the adhesive on the pedestals and install on the hood surface.

Tip: Hook the fingers on the pedestal over the hood edge and rotate the unit into position. After installation, remove the masking tape and “wet out” the tape to the hood surface by applying pressure with your thumb around the surface of the pedestals.

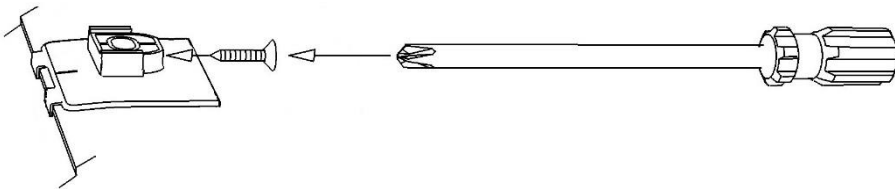

13. Start a #6 x 5/8 flat head screw into each pedestal a few turns. The tip of the screw must not protrude into the hole where the attachment pin will install later.

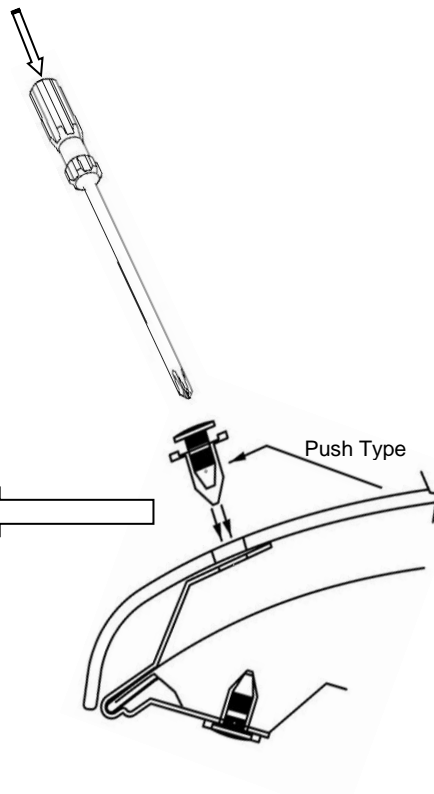

14. Place the hood protector on the hood resting on the three (3) metal brackets; align the 3 center holes in the protector with the holes in the metal brackets. Insert a “push type retainer” through the hole in the protector, and into the bracket. Ensure the protector is well seated against the surface of the metal bracket, and push the center pin of the retainer assembly to lock it into place.

NOTE: Engaging the center pin of the “push type retainer” is best accomplished by placing a #2 Philips drive screwdriver into the recess of the center pin. Use a light force or tap on the end of the screwdriver to seat the pin into the retainer. The retainer can be removed by unthreading the center pin in the conventional manner with a Philips screwdriver, however initial or subsequent placement is best performed using the “push” method described above.

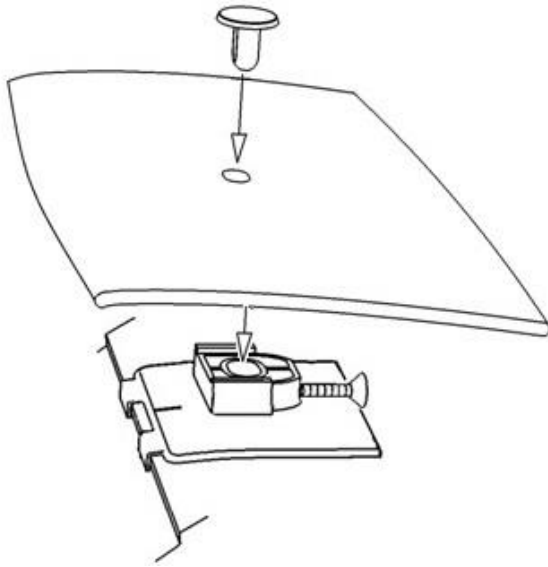

15. At the pedestal locations, drop a pin through the protector and into the pedestal.

16. Maintain slight pressure on the pin, to ensure proper seating of the components, while simultaneously tightening the screw.



CAUTION: Be sure to take care not to scratch or damage the hood surface while tightening the screw.

NOTE: Proper installation of the adhesive pedestal system requires the use of a #2 Phillips screwdriver, preferably with a long shaft. Use of the correct screw driver will facilitate a trouble free installation. Do not attempt to use #1 or smaller Phillips screwdriver or any type of electric screwdriver. **See illustration.**

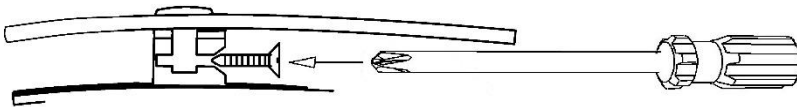

17. On some vehicles it may be necessary to adjust the hood bumpers and/or latch for proper clearance.

Note: Do not pull on the protector when opening or closing the hood.

CAUTION: Do not expose the vehicle/hood protector to extreme environments (weather) or car washes for a 24 hour period following the installation to allow the adhesive pedestals sufficient time to reach full bond strength.



CARE INSTRUCTIONS

Clean the protector with a mild soap and water solution or plastic cleaner only. Do not use chemicals or solvents.

Periodically check to make sure the bumpers are in place and the protector is secure. Avoid using automatic car washes. Do not pull on the protector when opening or closing the hood.